



A HELPFUL GUIDE TO MEASURING CURB SIZES

The following pages show the dimensions we require for manufacturing rooflights in a variety of situations.

Please select the plan that best suits your rooflight and fill in the required dimensions A, B & C. Please advise us if the pitch is steeper than the recommended 5° Scan and FAX or email to us with your order.

IMPORTANT: Always refer to our typical installation details available on our website before constructing your curb in order to ensure best appearance and fit. Black borders are available at extra cost for curbs wider than our standard recommendations as follows:

- Fixed Rooflights = 50mm wide curb
- Opening Rooflights = 100mm wide curb
- Minimum upstand height above roof finish = 150mm

For friendly, professional advice please call Tel 020 8801 4221 Opening Hours Mon-Thurs 08.30am to 5pm and Fri 08.30am to 4pm.

Lonsdale Metal Company Ltd
www.rooflightcentre.co.uk

Type A - No Wall Abutment

(Viewed from Outside)

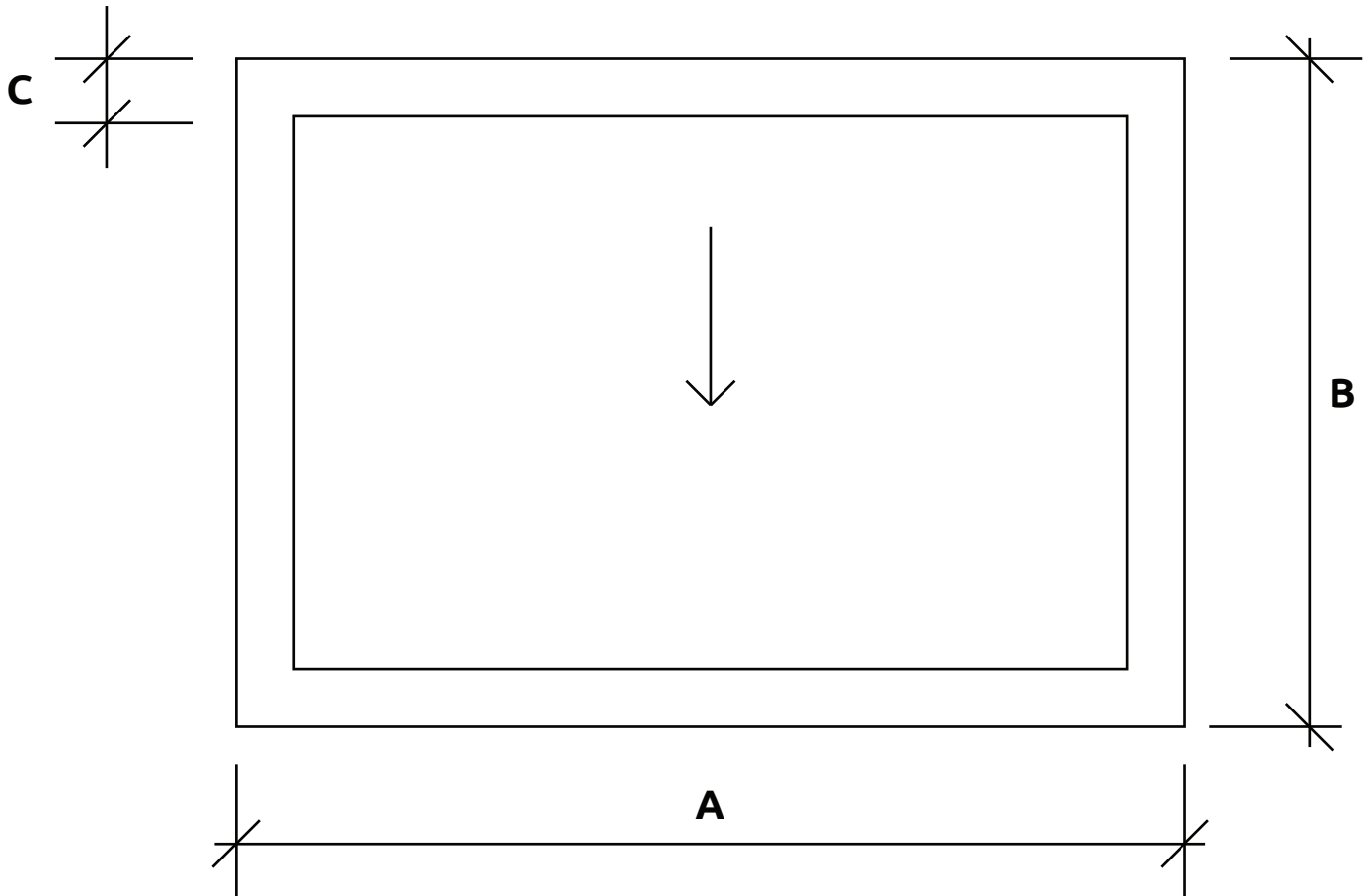

A = O/A Finished Curb Length (mm)

B = O/A Finished Curb Width (mm)

C = Width of Curb (Incl. Roof Finish) (mm)

↓ = Direction of Fall (Min 5° Recommended)
Over Shortest Dimension

Type B - Wall Abutment Top

(Viewed from Outside)

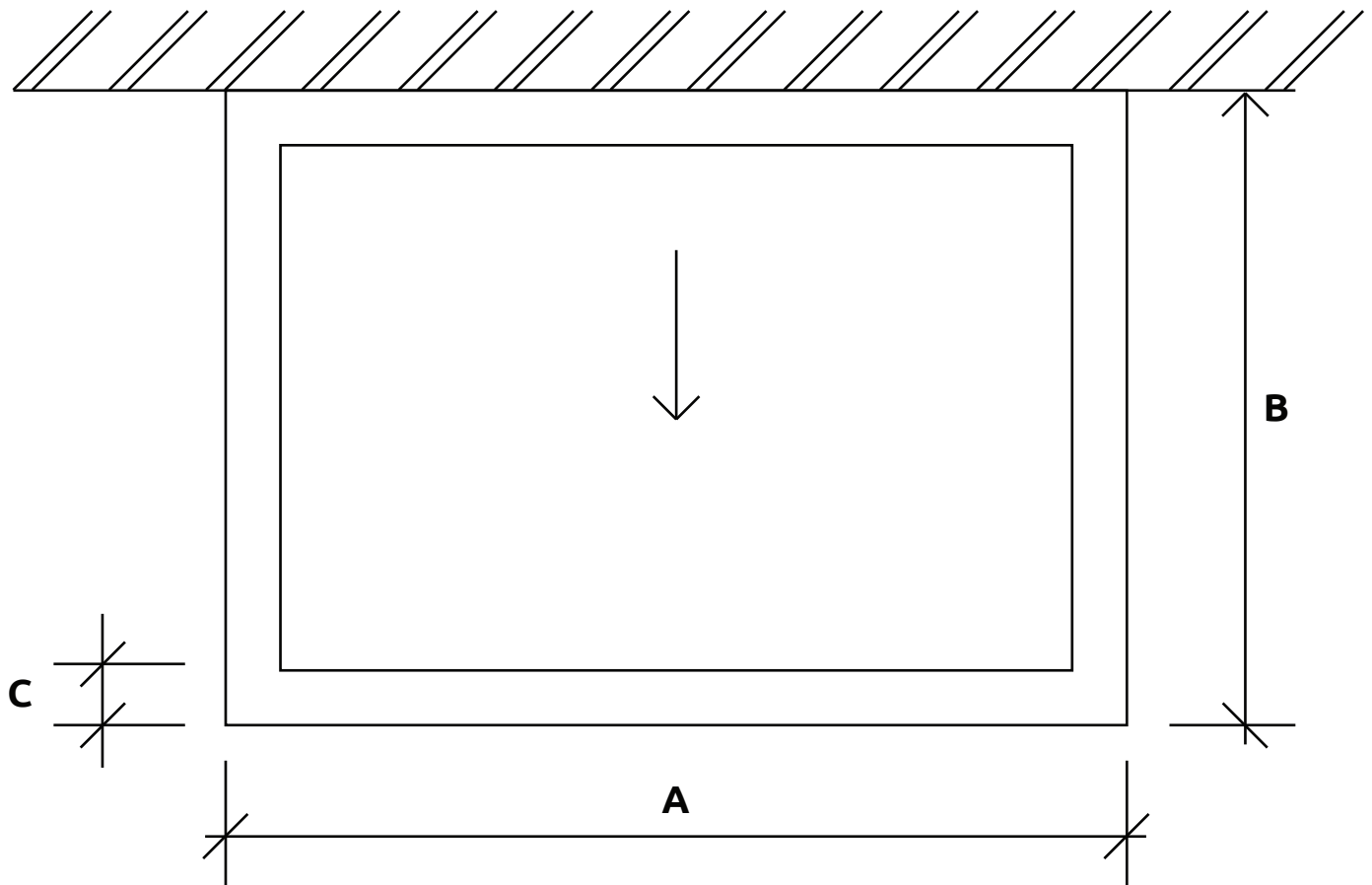

A = O/A Finished Curb Length (mm)

B = O/A Width from Wall to Outside Finished Curb (mm)

C = Width of Curb (Incl. Roof Finish) (mm)

↓ = Direction of Fall (Min 5° Recommended)
Over Shortest Dimension

Type C - Wall Abutment R/H Side (Viewed from Outside)

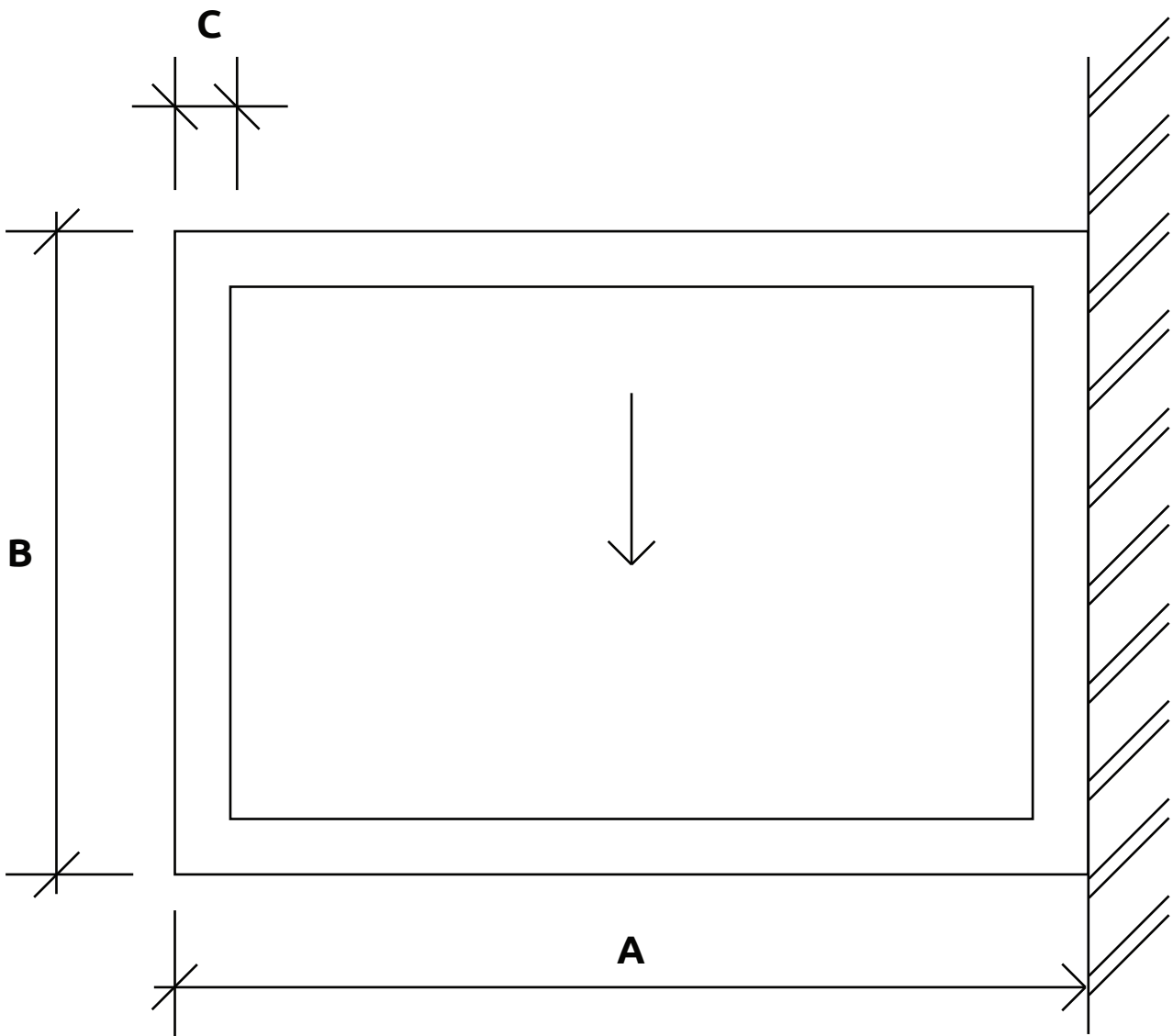

A = O/A Length from Wall to Outside Finished Curb (mm)

B = O/A Width from Wall to Outside Finished Curb (mm)

C = Width of Curb (Incl. Roof Finish) (mm)

↓ = Direction of Fall (Min 5° Recommended)
Over Shortest Dimension

Type D - Wall Abutment L/H Side (Viewed from Outside)

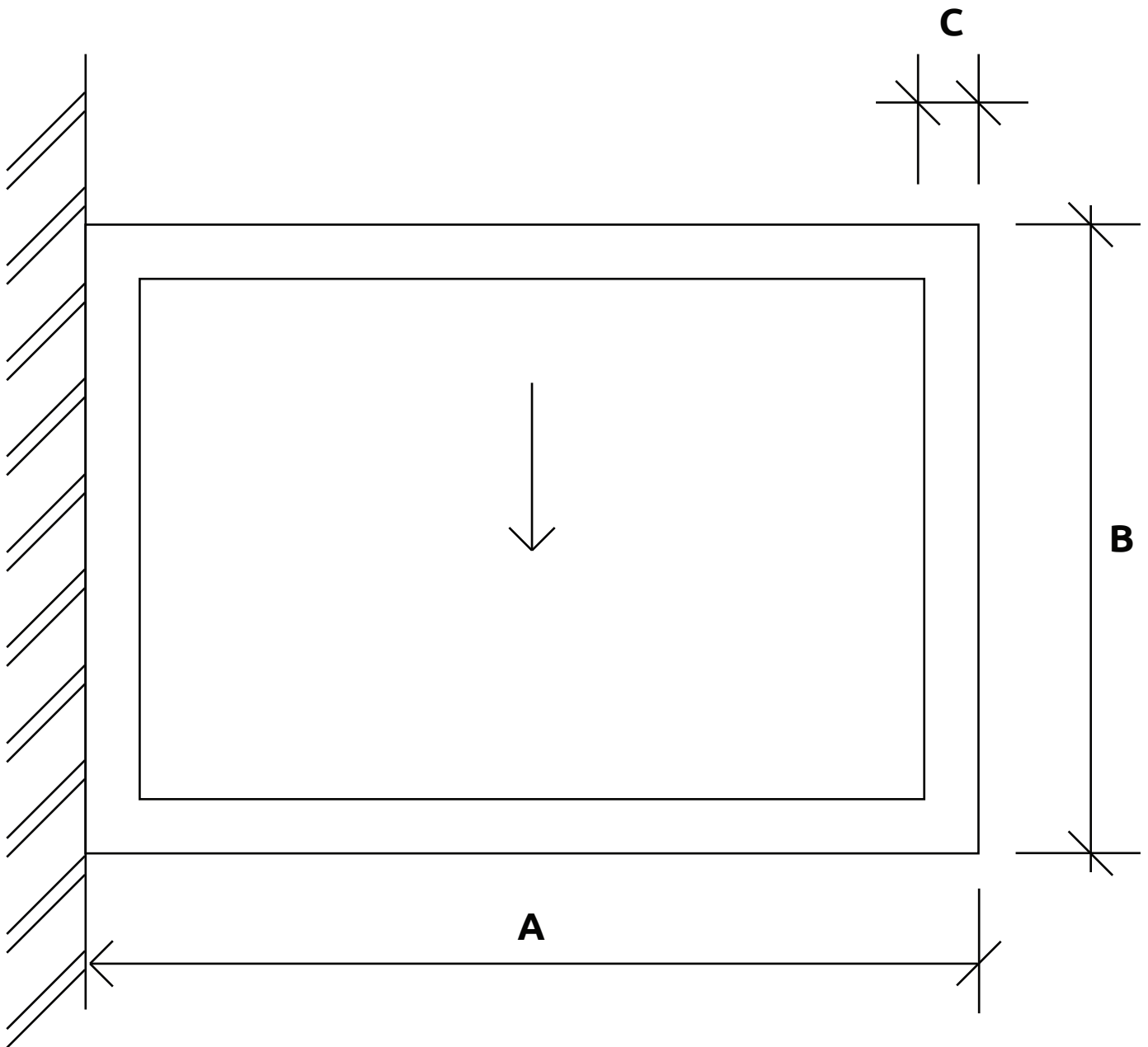

A = O/A Length from Wall to Outside Finished Curb (mm)

B = O/A Width from Wall to Outside Finished Curb (mm)

C = Width of Curb (Incl. Roof Finish) (mm)

↓ = Direction of Fall (Min 5° Recommended)
Over Shortest Dimension

Type E - Wall Abutment Top & One Side R/H

(Viewed from Outside)

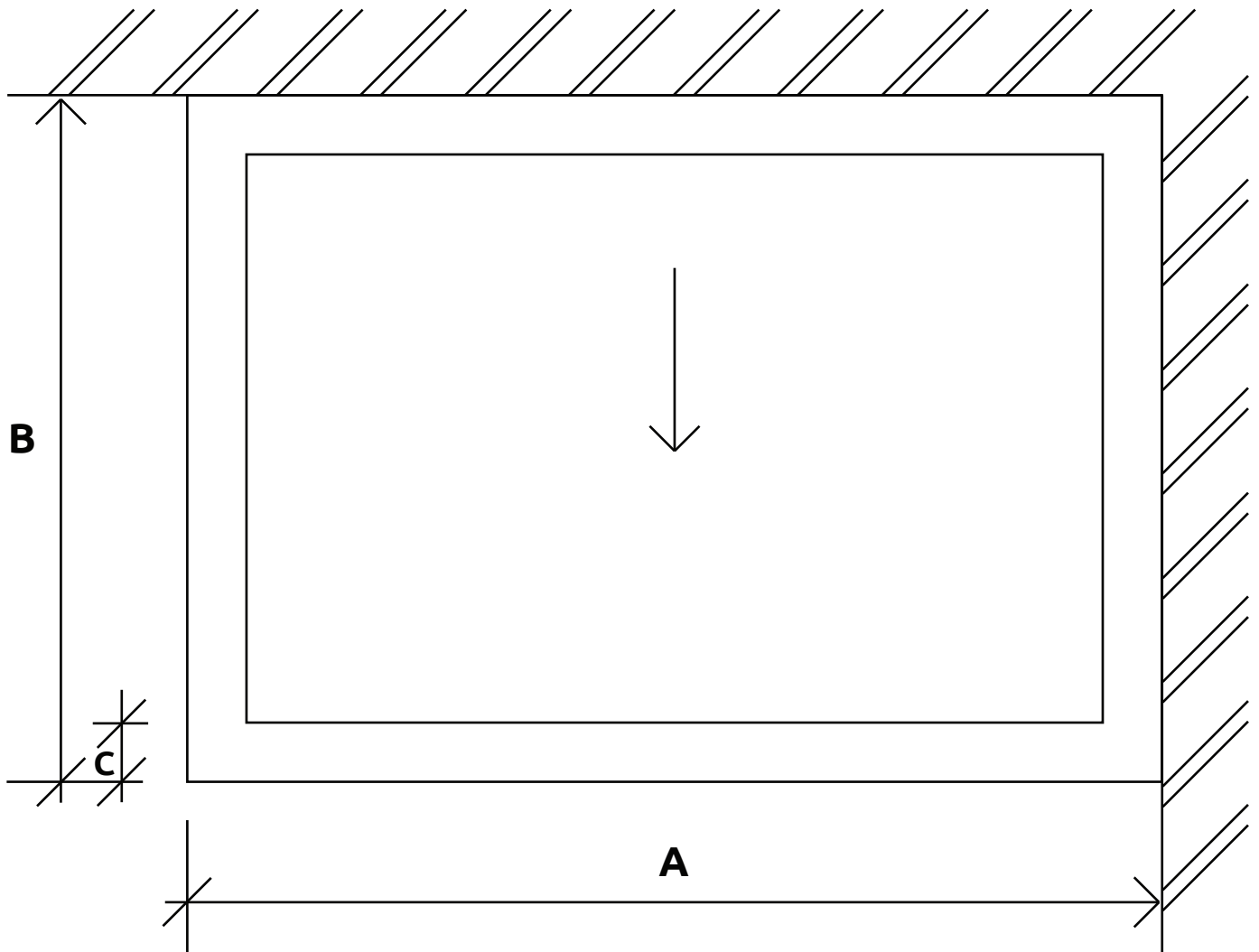

A = O/A Length from Wall to Outside Finished Curb (mm)

B = O/A Width from Wall to Outside Finished Curb (mm)

C = Width of Curb (Incl. Roof Finish) (mm)

↓ = Direction of Fall (Min 5° Recommended)
Over Shortest Dimension

Type F - Wall Abutment Top & One Side L/H

(Viewed from Outside)

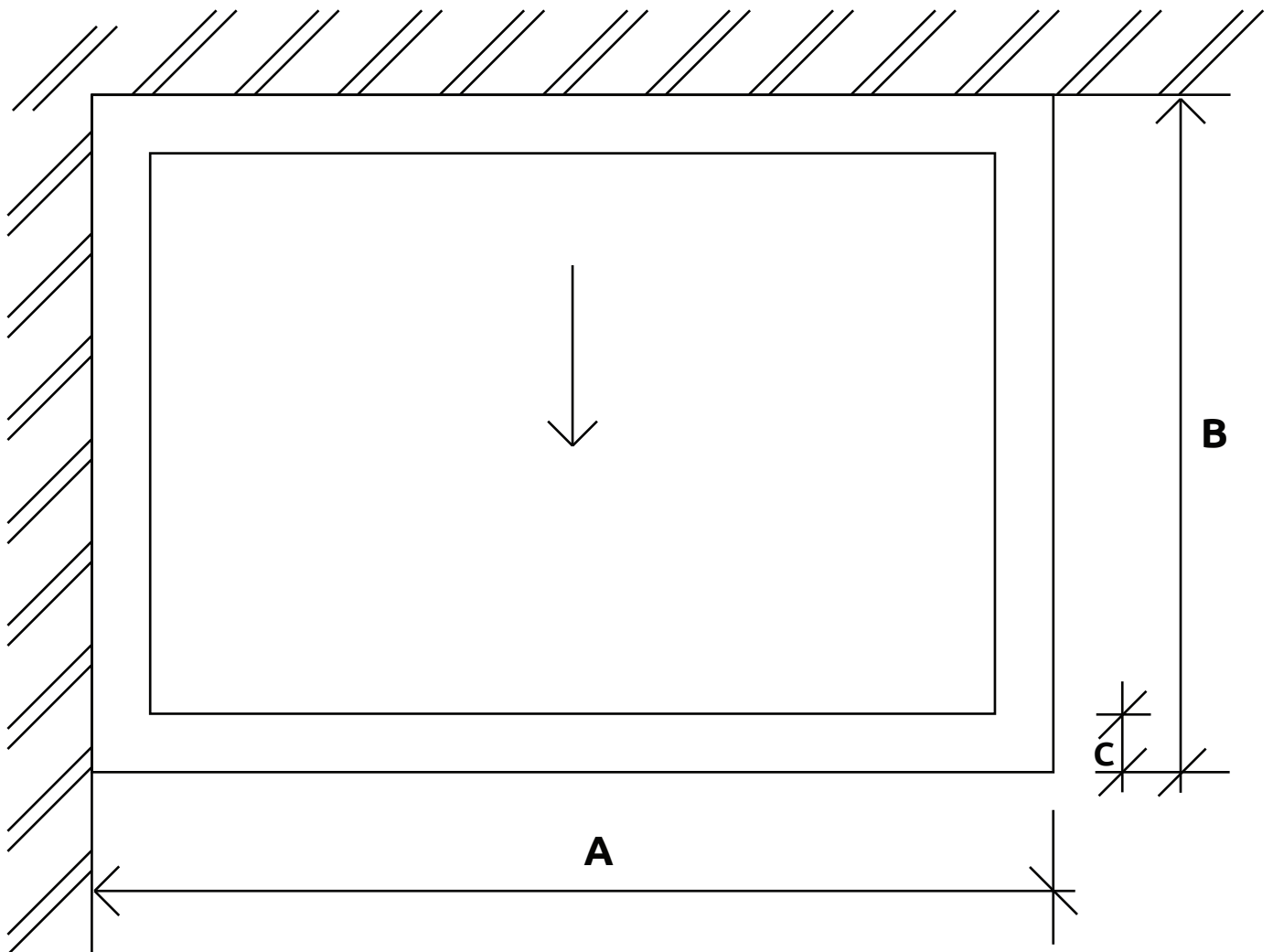

A = O/A Length from Wall to Outside Finished Curb (mm)

B = O/A Width from Wall to Outside Finished Curb (mm)

C = Width of Curb (Incl. Roof Finish) (mm)

↓ = Direction of Fall (Min 5° Recommended)
Over Shortest Dimension

Type G - Wall Abutment Top & Both Sides

(Viewed from Outside)

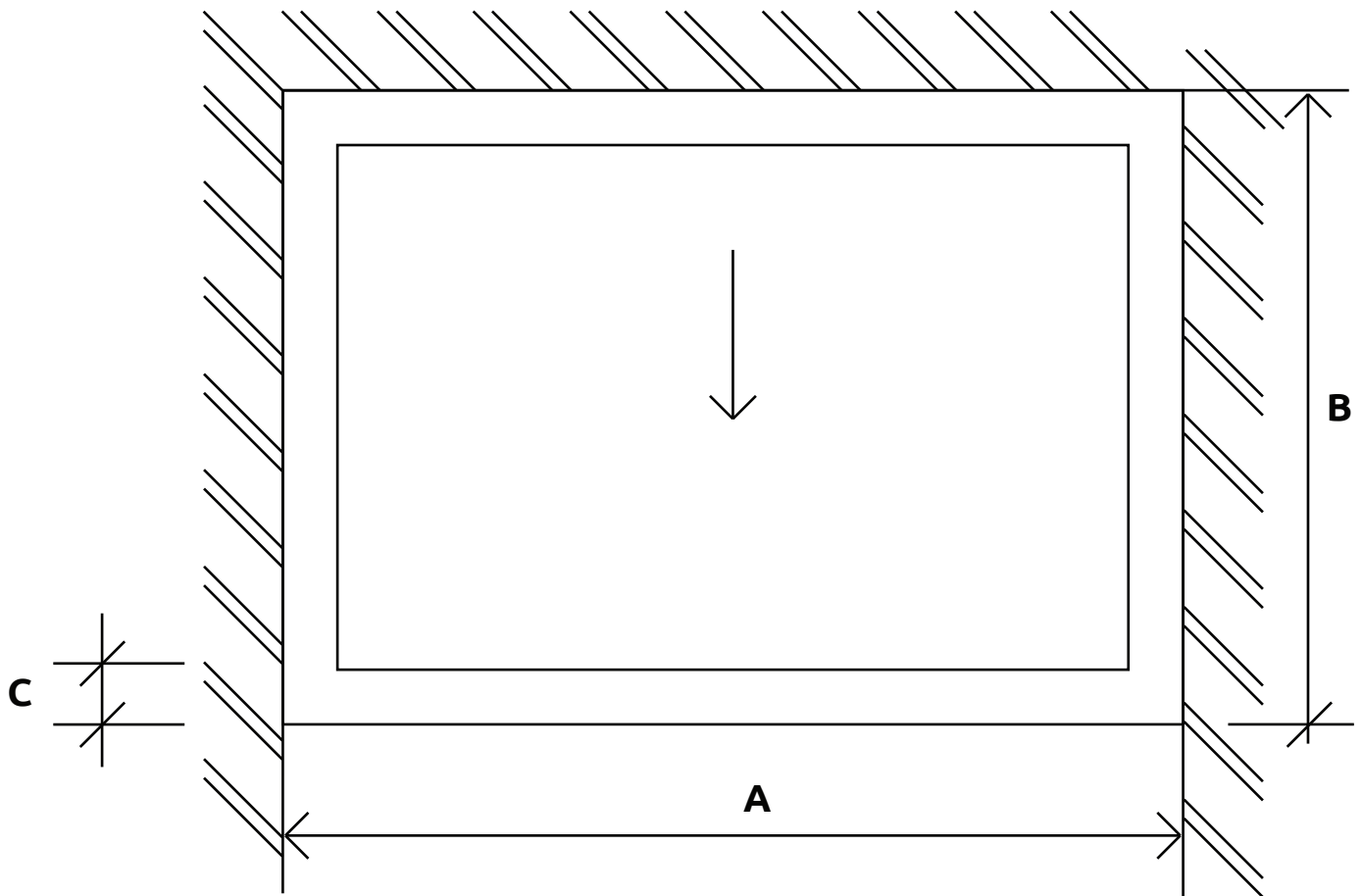

A = O/A Length Between Walls (mm)

B = O/A Width from Wall to Outside Finished Curb (mm)

C = Width of Curb (Incl. Roof Finish) (mm)

↓ = Direction of Fall (Min 5° Recommended)
Over Shortest Dimension

Type H - Wall Abutment Two Sides

(Viewed from Outside)

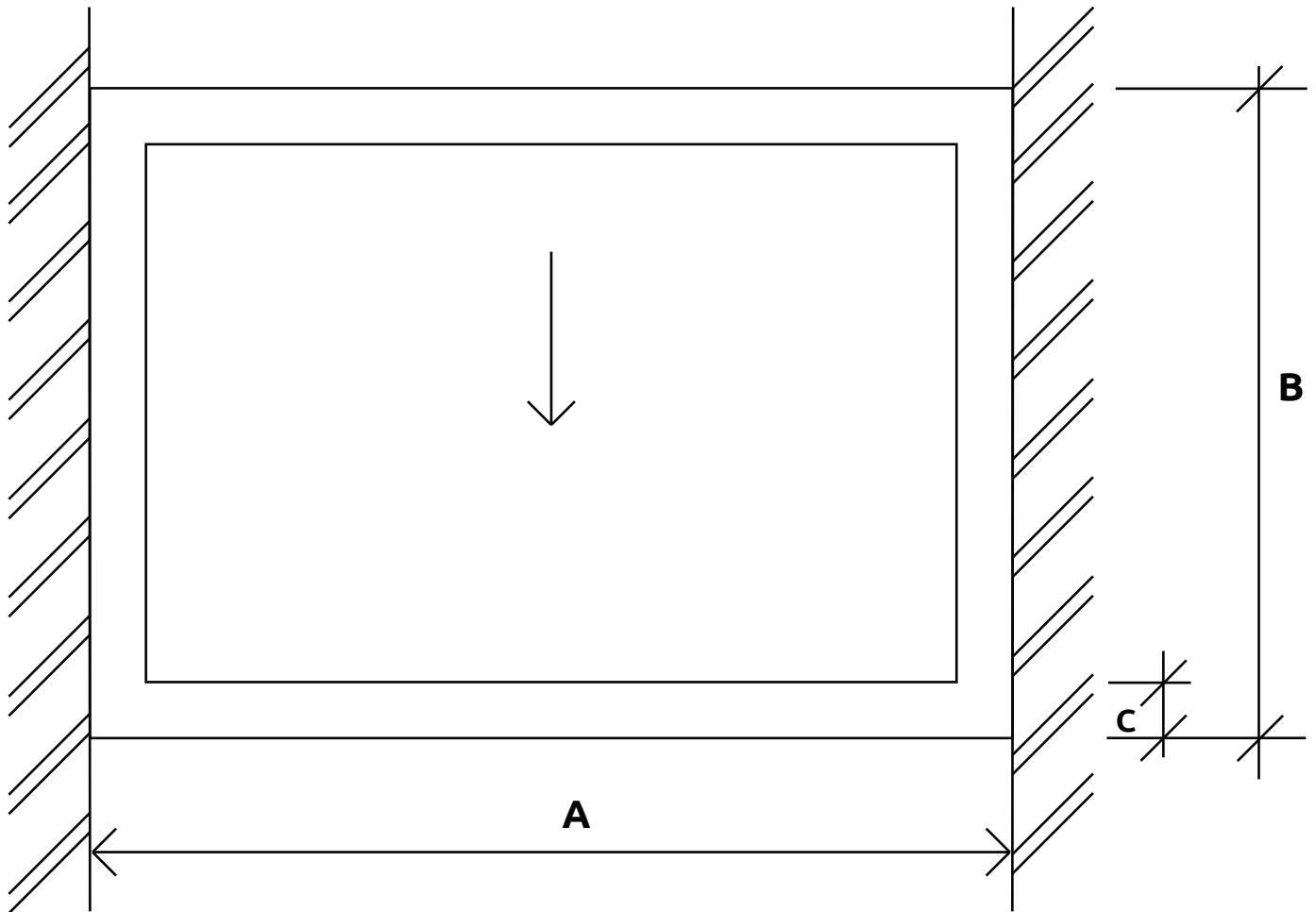

A = O/A Length Between Walls (mm)

B = O/A Finished Curb Width (mm)

C = Width of Curb (Incl. Roof Finish) (mm)

↓ = Direction of Fall (Min 5° Recommended)
Over Shortest Dimension